

INSTRUCTIONS FOR USE OF GESTEFAX STENCILS

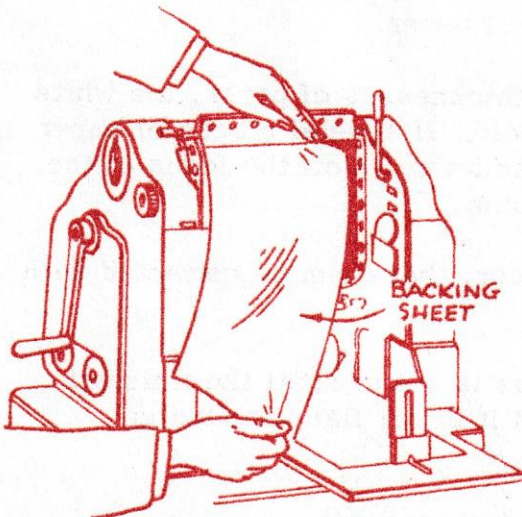

3. Place stencil on the Gestetner in the regular manner. After proofing, fold back the backing sheet and crease sharply all the way across at a point approximately 2" below the top edge of the stencil.
4. Tear off the backing sheet at crease and proceed to print copies.



1. Tear Backing sheet at bottom of stencil to a depth of approximately 1/2". This facilitates separation of stencil from backing sheet.
2. Peel stencil from backing sheet to within about 2" of the top edge. This 2" of backing sheet must be left attached to the stencil to hold securely on the Gestetner.

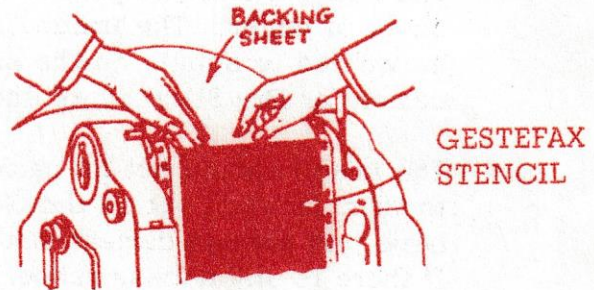

NOTE: Due to the nature of the GESTEFAX stencil, "Spotting Out" cannot be done prior to putting the stencil on the machine. It is necessary therefore, that this be done by the operator immediately before running off copies.

Gestetner Correctine/ should be used for "Spotting Out". Allow a few minutes to dry before starting run.

SUGGESTIONS FOR PREPARING COPY FOR GESTEFAX STENCILS

Please keep your original copy in a safe place, if you intend to have any more stencils made from it in the future.

Use a new black carbon ribbon or a new black nylon ribbon when preparing typewritten copy for reproduction.

The image, whether it is a photograph or something cut out of a magazine or newspaper, or a drawing, must be clear and with high contrast, and should be of the exact size to be reproduced. The limits that you have to adhere to in making layouts are 8-3/8" x 13-3/8".

The image should be placed on a GESTEFAX Layout Sheet or a WHITE sheet of paper. The image should be fitted into the exact location as wanted to appear on the stencil. Just a small amount of rubber cement or Dry Stick Spray should be used for paper sticking.

The image should not be cemented down completely, as it will tend to wrinkle when put on the Gestefax machine. The image should have just enough cement at the top edge to hold it on the paper. If there is any excess rubber cement on the copy it should be removed.

Do not type or write instructions on the copy to be reproduced. Put all instructions on a separate piece of paper.

Paste-ups should be limited to two thicknesses of paper, the white sheet underneath, and the image itself. If several pieces of paper are cemented on top of each other, this throws off the focus of the electronic eye on the Gestefax machine.

If any lines or undesirable spots occur, these can be corrected with our regular Gestetner Correctine.

A fold or crease on the original image is apt to spoil the finished result. When mailing in copy, send it either flat or rolled up.

H. & M. DUPLICATOR CORPORATION

2301 2nd Avenue MU 2-2341
Seattle, Wash. 98121